

Slice 2" Continuous Linear Multicell Downlight (54mm)

Surface/Pendant linear fixture

The Slice Family

Illuminate your space with precision Slices of glare free light. The Slice family offers linear 1" and 2" wide profiles in recessed and below ceiling options. The 2" Surface/Pendant delivers over 1100 lumens per foot with a modular design allowing continuous light of 2" square cells to your specified length. The unobtrusive fixture features ultra-low glare values (UGR) ≥ 13 . Offered in surface, cable and stem mounting, multiple CCTs, 2 outputs and 3 beam options, the slice 2" delivers.

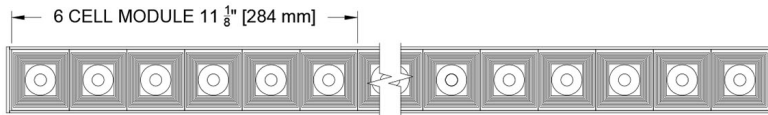
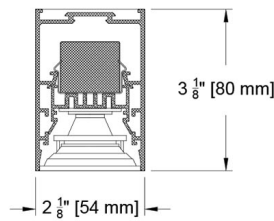
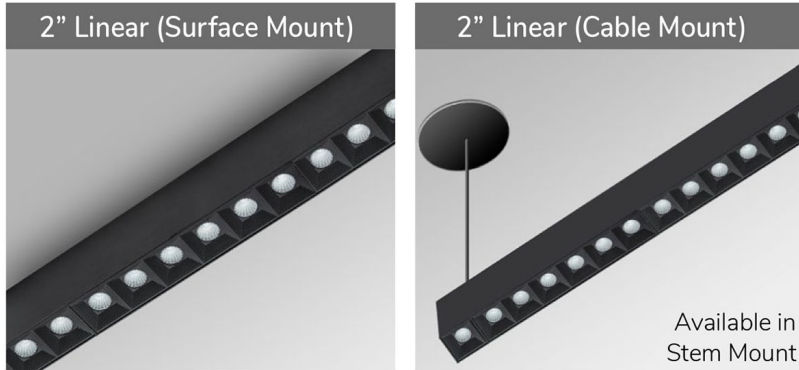

PROJECT:

TYPE:

SPECIFIER:

DATE:

Key Points (SL2DC-MCSF)

Source / Optics

- 3 beam spreads - 15°, 30° and 45°
- Up to 1126 Lumens/foot
- 70+ lumens per watt/foot
- Ultra low glare with UGR values <13
- <3 MacAdam Steps (<3 SDCM)
- CCT offerings - 2700k, 3000k, 3500k
- 90+ CRI and 50+ R9
- Supports CA Title 24 part 6 compliance meeting JA8 requirements

Housing

- 14 available housing finishes+ custom/RAL available
- 3 mounting types - Surface, Stem and Cable
- Profile allows continuous light from 6 cells to your desired length in 6 cell increments.
- Lengths longer than 8' are assembled in the field with supplied joiners
- Damp listed

Driver And Control

- Integral Driver in selections greater than 6 cells
- 0.1% dimming available in 0-10 or DALI-2 protocols
- Flicker Free to IEEE 1789-2015 (no effect to low risk)
- Universal 120v to 277v

Lumens and Length per 6 Cell Module											
2" Slice		Length		Flux and Power (SO8)				Flux and Power (SO15)			
Modules	Cells	English (in)	Metric (mm)	Delivered Lm			System Watts	Delivered Lm			System Watts
				15°	30°	45°		15°	30°	45°	
1	6	11 3/8	289	629	603	608	8	1062	1065	1072	15
2	12	22 5/8	573	1258	1206	1216	14	2124	2130	2144	27
3	18	33 3/4	858	1887	1809	1824	20	3186	3195	3216	39
4	24	45	1142	2516	2412	2432	25	4248	4260	4288	50
5	30	56 1/8	1427	3145	3015	3040	31	5310	5325	5360	62
6	36	67 3/8	1711	3774	3618	3648	37	6372	6390	6432	77
7	42	78 5/8	1995	4403	4221	4256	43	7434	7455	7504	89
8	48	89 3/4	2280	5032	4824	4864	49	8496	8520	8576	101

Refer to Photometric page for lumens/ft values

Slice 2" Continuous Linear Multicell Downlight (54mm)



Surface/Pendant linear fixture

Ordering Codes

PROJECT: _____ SPECIFIER: _____

DATE: _____ TYPE: _____ QUANTITY: _____

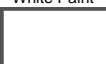
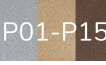
Ordering Code Example: SL2DC-MCSF-SM-B-48-SO15-30-45-SY1-P16

FIXTURE	MOUNTING	LENGTH	CELLS	SOURCE / WATTS	CCT	BEAM	DRIVER / CONTROL	HOUSING FINISH
SL2DC-MCSF								
Slice 2" Continuous Linear Surface/Pendant Multicell Downlight	SM Surface Mount	B Blank - use for surface mount	6 11 3/8" (289mm)*	SO8 ●● 8W/ft 661Lm/ft* 90+CRI, 50+R9 Specialty Board	27 2700K	15 Spot	SY1 0-10 1.0%, UNV (120-277V) linear	Standard B Black Paint  Optional W White Paint  PXX Specialty Paint Color*  C Custom/RAL*  Note: Baffle is black only *See Finish Guide 
	CBM Cable Mount	- Specify Length of Stem or Cable in inches	12 22 3/8" (573mm)	SO15 ●● 16W/ft 1116Lm/ft* 90+CRI, 50+R9 Specialty Board	30 3000K	30 Narrow Flood	SY2 0-10 1.0%, UNV (120-277V) log	
	STM Stem Mount		18 33 3/4" (858mm)		35 3500K	45 Flood	E1 0-10 0.1%, UNV (120-277V) log	
			24 45" (1142mm)				E2 DALI-2 0.1%, UNV (120-277V) log	
			30 56 1/8" (1427mm)	*Extrapolated from 6 cell (11.375")15" module. Refer to photometric table for more exact power and lumen data			E3 0-10 0.1%, UNV (120-277V) linear	
			36 67 3/8" (1711mm)	●● Supports CA T24 part 6 compliance meeting JA8 requirements			Note: Integral driver except for 6 cell selection requiring alternative remote driver	
			42 78 5/8" (1995mm)					
			48 89 3/4" (2280mm)					
			-- specify total # of cells in 6 cell increments if over 48 cells^					
			^ Lengths > 96" are shipped in 96" sections and assembled with engineered joiner					
		*Requires remote driver						

Fixture Lengths

Standard lengths are shown below. Longer continuous runs are available. Simply specify the total number of cells, in 6 cell increments, for lengths longer than 48 cells.

SL2DC- Standard Modular Configurations (6 cell runs)

(SL2DC-MCSF-)

1 MODULE
6 CELLS



REMOTE DRIVER REQUIRED

2 MODULES
12 CELLS



3 MODULES
18 CELLS



4 MODULES
24 CELLS



5 MODULES
30 CELLS



6 MODULES
36 CELLS



7 MODULES
42 CELLS



8 MODULES
48 CELLS

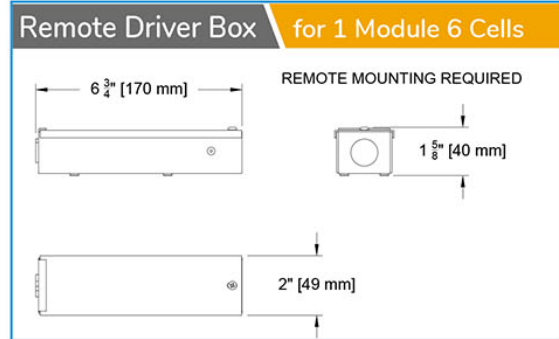
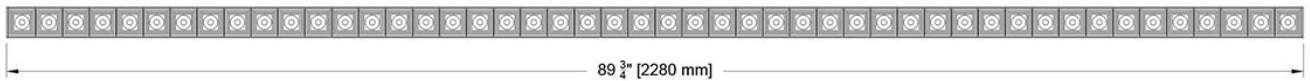

Ceiling Cutouts and Dimensions

For lengths over 48 cells a submittal drawing is required.

SL2DC- Surface Mount Multicell Housing

SM

(SL2DC-MCSF-SM)

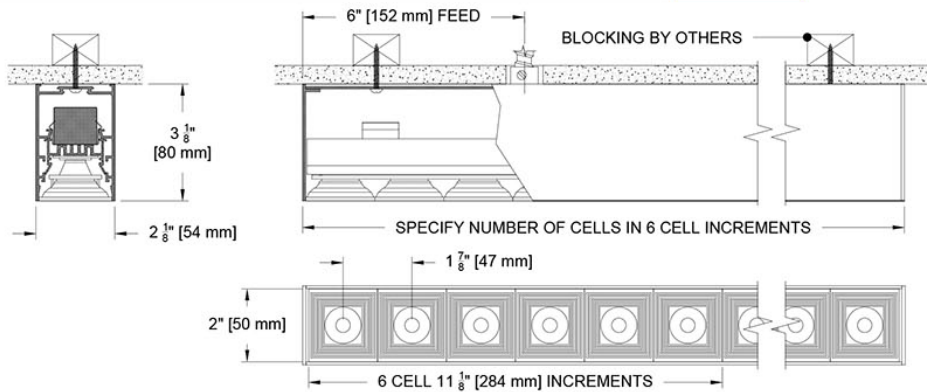

SL2DC- Cable Mount Multicell Housing

CBM

(SL2DC-MCSF-CBM)

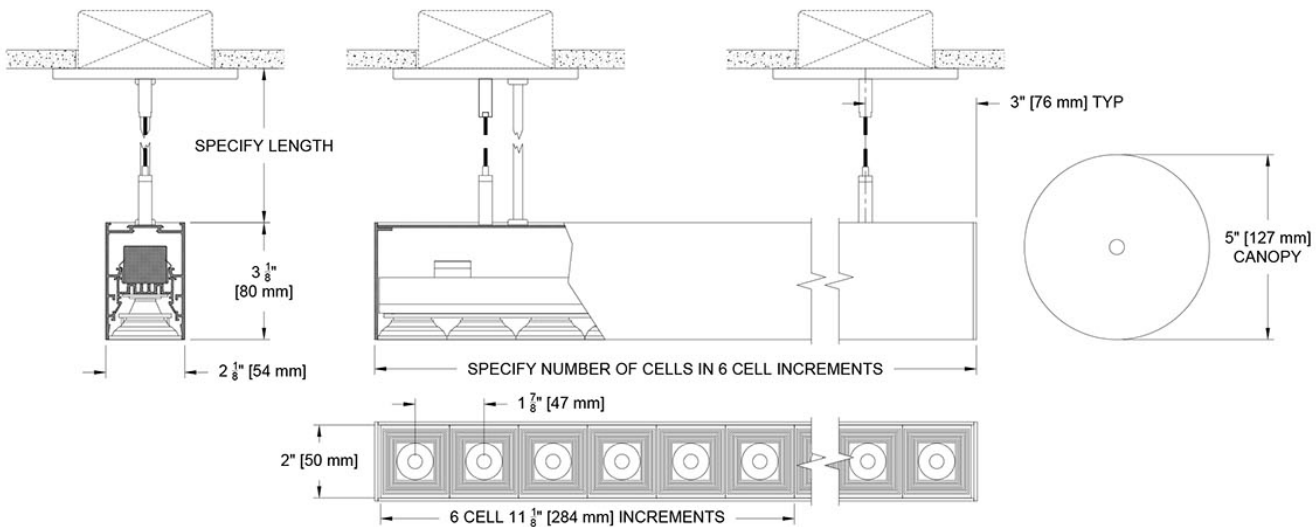

SL2DC- Pendant Mount Multicell Housing

STM

(SL2DC-MCSF-STM)

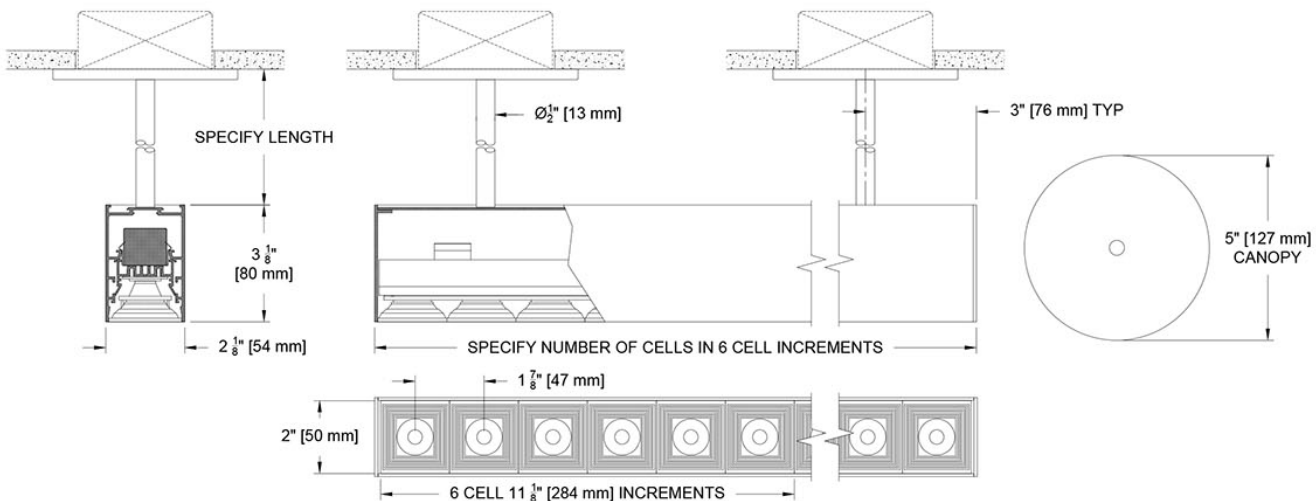

Photometric Table

Values are delivered lumens based on a 6-cell module at 11.125" (284mm) and extrapolated for per foot numbers. CAUTION: IES FILES ARE FOR A 6 CELL MODULE. CALCULATIONS MUST PLACE THE 6 CELL MODULE FILE 11.125" (284mm) ON CENTER FOR THE ENTIRE SPECIFIED LENGTH OF FIXTURE. All data is based on goniometer measurements of production representative product. Measurements are taken at 3000 CCT with a black baffle and can vary +/- 10% from LED manufacturer rated flux range.

Lumens per Foot Photometrics													
Multi-Cell Beamspreads		15°				30°				45°			
Source	System watts (W)	Delivered Lumens (lm/ft)	Lumens/Watt/ft	Peak (cd)	10% Field	Delivered Lumens (lm/ft)	Lumens/Watt/ft	Peak (cd)	10% Field	Delivered Lumens (lm/ft)	Lumens/Watt/ft	Peak (cd)	10% Field
SO8	8	661	80	4287	42°	634	76	1893	59°	639	77	1170	69°
SO15	16	1116	70	7673	41°	1119	71	3362	59°	1126	71	2098	69°
CCT Multiplier		<p>Beam angle 15.6°</p>				<p>Beam angle 30.4°</p>				<p>Beam angle 44.5°</p>			
CCT	Citizen												
2700	0.95												
3000	1.00												
3500	1.05												
4000	1.1												
ISO CD plot based on SO8 source. UGR values are from 4H 3H row and based on per foot extrapolation.													

Lumens and Length per 6 Cell Module											
2" Slice		Length		Flux and Power (SO8)				Flux and Power (SO15)			
Modules	Cells	English (in)	Metric (mm)	Delivered Lm			System Watts	Delivered Lm			System Watts
				15°	30°	45°		15°	30°	45°	
1	6	11 3/8	289	629	603	608	8	1062	1065	1072	15
2	12	22 5/8	573	1258	1206	1216	14	2124	2130	2144	27
3	18	33 3/4	858	1887	1809	1824	20	3186	3195	3216	39
4	24	45	1142	2516	2412	2432	25	4248	4260	4288	50
5	30	56 1/8	1427	3145	3015	3040	31	5310	5325	5360	62
6	36	67 3/8	1711	3774	3618	3648	37	6372	6390	6432	77
7	42	78 5/8	1995	4403	4221	4256	43	7434	7455	7504	89
8	48	89 3/4	2280	5032	4824	4864	49	8496	8520	8576	101

Color Data

All data is based from goniometer measurements of production representative product. All lumen values can vary +/- 10% from LED manufacturer rated data range. Measurements at 3000 CCT unless otherwise noted.

SO8 and SO15

- <3 MacAdam Ellipse (<3 SDCM)
- 90+ CRI and RF
- 50+R9, Hue Bin 1 and 16

